

Package Leaflet: Information for the User

IMIGRAN[®] NASAL SPRAY

10 mg and 20 mg
sumatriptan

Read all of this leaflet carefully before you start taking this medicine because it contains important information for you.

- Keep this leaflet. You may need to read it again.
- If you have any further questions, ask your doctor or pharmacist.
- This medicine has been prescribed for you only. Do not pass it on to others - it may harm them, even if their signs of illness are the same as yours.
- If you get any side effects, talk to your doctor or pharmacist. This includes any possible side effects not listed in this leaflet. See section 4.

What is in this leaflet

- 1 What Imigran nasal spray is and what it is used for
- 2 What you need to know before you use Imigran nasal spray
- 3 How to use Imigran nasal spray
- 4 Possible side effects
- 5 How to store Imigran nasal spray
- 6 Contents of the pack and other information

1 What Imigran nasal spray is and what it is used for

Each Imigran nasal spray contains a single dose of sumatriptan, which belongs to a group of medicines called triptans (*also known as 5-HT₁ receptor agonists*).

Imigran nasal spray is used to treat migraine headache.

Migraine symptoms may be caused by the temporary widening of blood vessels in the head. Imigran nasal spray is believed to reduce the widening of these blood vessels. This in turn helps to take away the headache and relieve other symptoms of a migraine attack, such as feeling or being sick (nausea or vomiting) and sensitivity to light and sound.

2 What you need to know before you use Imigran nasal spray

Don't use Imigran:

- **If you're allergic** to sumatriptan, or any of the other ingredients of this medicine (listed in section 6).
- **If you have a heart problem** such as narrowing of the arteries (*Ischaemic heart disease*) or chest pains (*angina*), or have already had a heart attack.

- **If you have circulation problems in your legs** that cause cramp-like pains when you walk (*peripheral vascular disease*).
- **If you have had a stroke** or a mini-stroke (*also called a transient ischaemic attack or TIA*).
- **If you have high blood pressure.** You may be able to use Imigran if your high blood pressure is mild and is being treated.
- **If you have serious liver disease.**
- **With other migraine medicines**, including those which contain ergotamine, or similar medicines such as methysergide or any triptan/5-HT₁ receptor agonist (medicines which are also used for treating migraine).
- **With anti-depressants called MAOIs** (*monoamine oxidase inhibitors*), or if you have taken these medicines in the last 2 weeks.

If any of these apply to you:

➔ **Tell your doctor, and don't use Imigran nasal spray.**

Take special care with Imigran

Talk to your doctor or pharmacist before using Imigran.

If you have any extra risk factors

- **If you are a heavy smoker**, or are using **nicotine replacement therapy**, and especially
- **If you are a man aged over 40**, or
- **If you are a woman who has been through the menopause.**

In very rare cases, people have developed serious heart conditions after using Imigran, even though they had no signs of heart disease before. If any of the points above applies to you it could mean you have a greater risk of developing heart disease - so:

➔ **Tell your doctor so that your heart function can be checked** before Imigran is prescribed for you.

If you have a history of fits (*seizures*)

Or if you have other conditions which might make it more likely that you'll have a fit – for example, a head injury or alcoholism.

➔ **Tell your doctor so that you can be supervised more closely.**

If you have liver or kidney disease

➔ **Tell your doctor so that you can be supervised more closely.**

If you are allergic to antibiotics called sulphonamides

If so, you may also be allergic to Imigran. If you know you are allergic to an antibiotic but you are not sure whether it is a sulphonamide:

➔ **Tell your doctor or pharmacist before using Imigran.**

If you are taking anti-depressants called SSRIs (*Selective Serotonin Reuptake Inhibitors*) or SNRIs (*Serotonin Noradrenaline Reuptake Inhibitors*)

➔ **Tell your doctor or pharmacist before using Imigran.** Also see *Other medicines and Imigran*, below.

If you use Imigran frequently

Using Imigran too often may make your headaches worse.

➔ **Tell your doctor if this applies to you.** He or she may recommend you stop using Imigran.

If you feel pain or tightness in your chest after you use Imigran

These effects may be intense but they usually pass quickly. If they don't pass quickly, or they become severe:

➔ **Get medical help immediately.** Section 4 of this leaflet has more information about these possible side effects.

Other medicines and Imigran

Tell your doctor or pharmacist if you're taking, have recently taken or might take any other medicines. This includes any herbal products or medicines you've bought without a prescription.

Some medicines must not be taken with Imigran and others may cause adverse effects if they're taken with Imigran. **You must tell your doctor if you are taking:**

- **ergotamine** also used to treat **migraine**, or similar medicines such as methysergide (see Section 2). Don't use Imigran at the same time as these medicines. Stop taking these medicines at least 24 hours before using Imigran. Don't take any medicines which contain ergotamine or compounds similar to ergotamine again for at least 6 hours after using Imigran.
- **other triptans/5-HT₁ receptor agonists** (such as naratriptan, rizatriptan, zolmitriptan), also used to treat **migraine**, (see Section 2). Don't use Imigran at the same time as these medicines. Stop taking these medicines at least 24 hours before using Imigran. Don't take another triptan/5-HT₁ receptor agonist again for at least 24 hours after using Imigran.
- **SSRIs** (*Selective Serotonin Reuptake Inhibitors*) or **SNRIs** (*Serotonin Noradrenaline Reuptake Inhibitors*) used to treat **depression**. Using Imigran with these medicines can cause serotonin syndrome (a collection of symptoms which can include restlessness, confusion, sweating, hallucinations, increased reflexes, muscle spasms, shivering, increased heartbeat and shaking). Tell your doctor immediately if you are affected in this way.
- **MAOIs** (*monoamine oxidase inhibitors*) used to treat **depression**. Don't use Imigran if you have taken these in the last 2 weeks.
- **St John's Wort** (*Hypericum perforatum*). Taking herbal remedies that contain St John's Wort while you are using Imigran may make side effects more likely.

Pregnancy and breast-feeding

- **If you are pregnant, think you may be pregnant or are planning to have a baby**, ask your doctor for advice before taking this medicine. There is only limited information about the safety of Imigran for pregnant women, though up until now there is no evidence of any increased risk of birth defects. Your doctor will discuss with you whether or not you should use Imigran while you are pregnant.
- **Don't breast-feed your baby for 12 hours after using Imigran.** If you express any breast milk during this time, discard the milk and don't give it to your baby.

Driving and using machines

Either the symptoms of migraine or your medicine may make you drowsy. **If you are affected, don't drive or operate machinery.**

3 How to use Imigran nasal spray

Only use Imigran after your migraine headache begins

Don't use Imigran to try to prevent an attack.

Always use this medicine exactly as your doctor has told you. Check with your doctor or pharmacist if you are not sure.

There's a **step-by-step guide** to using the spray at the end of this section.

How much to use

Adults aged 18 to 65

- **The usual dose for adults aged 18 to 65** is one Imigran 20 mg spray into just one nostril. But one Imigran 10 mg spray into one nostril is enough for some people. Don't use more than two sprays in 24 hours.

Adolescents aged 12 to 17

- **The usual dose for adolescents aged 12 to 17** is one Imigran 10 mg spray into one nostril.

Children under 12

- **Imigran nasal spray is not recommended** for children under 12 years old.

Older people (aged over 65)

- **Imigran nasal spray is not recommended** for people aged over 65.

When to use Imigran

- **It's best to use Imigran as soon as you feel a migraine coming on**, although it can be used at any time during an attack.

If your symptoms start to come back

- You can use a second Imigran nasal spray after 2 hours, but **don't use more than two sprays in 24 hours**.

If the first spray has no effect

- **Don't use a second spray**, or any other Imigran preparation for the same attack. If Imigran doesn't give you any relief:
➔ **Ask your doctor or pharmacist for advice.**

If you use more Imigran than you should

- **Don't use more than two Imigran nasal sprays in 24 hours.** Using too much Imigran could make you ill. If you have used more than two sprays in 24 hours:
➔ **Contact your doctor for advice.**

If you have any further questions on the use of this medicine, ask your doctor or pharmacist.

Step-by-step guide to using your Imigran nasal spray

Don't open a blister until you are ready to use a spray. Each spray is sealed in a blister to keep it clean and safe. If you carry a spray without a blister, or in an open blister, it may not work properly when you need it.

Each spray contains just one dose of Imigran.

Don't press the plunger too soon or you will lose the dose.

Imigran nasal spray has three parts:

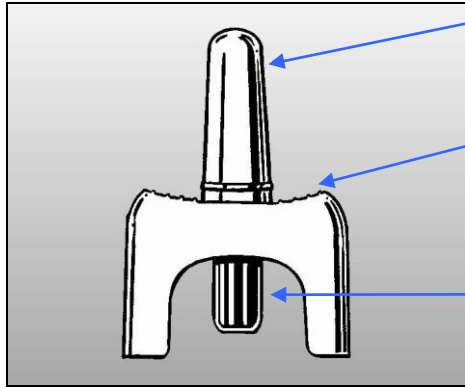

The nozzle

The part that you put into your nostril.
The spray comes out of a tiny hole in the top.

The finger-grip

Hold this when you use the spray.

The blue plunger

Press this to spray the whole dose into your nostril in one go. This only works once - **don't press the plunger until you have put the nozzle into your nostril or you will lose the dose.**

How to use the nasal spray

- 1 Remove the nasal spray** from the blister packaging just before you want to use it.
- 2 Get into a comfortable position.** You may prefer to sit down.
- 3 Blow your nose** if it feels blocked, or if you have a cold.
- 4 Hold the nasal spray** gently with your fingers and thumb, as shown in picture **A**.
Don't press the blue plunger yet.

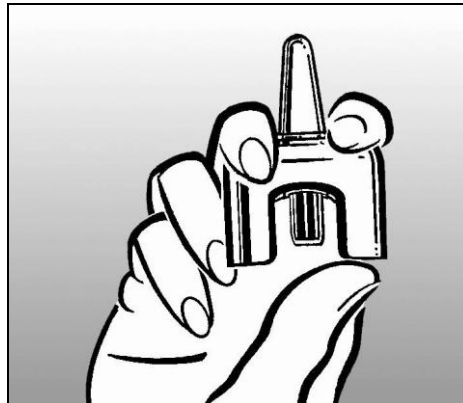

- 5 Block one nostril** by pressing a finger firmly on the side of your nose. It doesn't matter which nostril you choose.



- 6 Put the nozzle of the nasal spray into the other nostril, as far as feels comfortable - about 1 cm or 1/2 inch (picture B).**
Breathe out gently through your mouth.
Hold your head upright and close your mouth.



- 7 Start to breathe in gently through your nose.**
As you breathe in:
Press the blue plunger firmly with your thumb.
The plunger may feel a bit stiff and you may hear it click. Keep breathing in while spraying (picture C).
- 8 Remove the spray and remove your finger from the side of your nose.**
Keep your head upright for 10-20 seconds, breathing gently in through your nose and out through your mouth. This helps the medicine stay in your nose.
Your nose may feel wet inside and you may notice a slight taste after using the spray - this is normal and will soon pass.
- 9 Your nasal spray is now empty.** Throw it away safely and hygienically.

4 Possible side effects

Like all medicines, this medicine can cause side effects, but not everybody gets them.

Some symptoms may be caused by the migraine itself.

Adverse events reported in adults have also been observed in adolescents. These include very rare reports of heart attacks.

Allergic reaction: get doctor's help straight away

The following side effects have occurred but their frequency is not known.

- **The signs of allergy include rash, hives (itchy rash); wheezing; swollen eyelids, face or lips; complete collapse.**

If you get any of these symptoms soon after using Imigran:

➔ **Don't use any more. Contact a doctor straight away.**

Very common side effects

(affect more than **1 in 10** people)

- **Unpleasant taste.**

Common side effects

(affect up to **1 in 10** people)

- **Heaviness, pressure, tightness or pain in the chest**, throat or other parts of the body, or feelings of unusual sensations, including numbness, tingling and warmth or cold. These effects may be intense but generally pass quickly.

If these effects continue or become severe (especially the chest pain):

➔ **Get medical help urgently.** In a very small number of people these symptoms can be caused by a heart attack.

Other common side effects include:

- **Irritation** or burning sensation in the nose or throat; nose bleeds.
- **Feeling sick** (nausea) or being sick (vomiting), although this may be due to the migraine itself.
- **Tiredness** or drowsiness.
- **Dizziness**, feeling weak, or getting hot flushes.
- **Temporary increase in blood pressure.**
- **Shortness of breath.**
- **Aching muscles.**

Very rare side effects

(affect up to **1 in 10,000** people)

- Liver function changes. If you have a blood test to check your liver function, tell your doctor or nurse that you are using Imigran.

Some patients may have the following side effects but it is not known how often they occur

- Seizures/fits, tremors, muscle spasm, neck stiffness.
- Visual disturbances such as flickering, reduced vision, double vision, loss of vision and in some cases even permanent defects (although these may be due to the migraine attack itself).
- Heart problems, where your heart beat may go faster, slower or change rhythm, chest

- pains (*angina*) or heart attack.
- Pale blue-tinged skin and/or pain in your fingers, toes, ears, nose or jaw in response to cold or stress (*Raynaud's phenomenon*).
 - Feeling faint (blood pressure may go down).
 - Pain in the lower left side of the stomach and bloody diarrhoea (*ischaemic colitis*).
 - Diarrhoea.
 - Pain in the joints.
 - Feeling anxious.
 - Excessive sweating.

Reporting of side effects

If you get any side effects, talk to your doctor, pharmacist or nurse. This includes any possible side effects not listed in this leaflet. You can also report side effects directly via the Yellow Card Scheme at www.mhra.gov.uk/yellowcard. By reporting side effects you can help provide more information on the safety of this medicine.

5 How to store Imigran nasal spray

Keep this medicine out of the sight and reach of children.

Keep this medicine in the sealed blister in the box to protect it from light.

Don't store above 30°C and don't freeze.

Don't use this medicine after the expiry date shown on the carton. The expiry date refers to the last day of that month.

Don't throw away any medicines via wastewater or household waste. Ask your pharmacist how to throw away medicines you no longer use. These measures will help protect the environment.

6 Contents of the pack and other information

What Imigran nasal spray contains

The active substance is sumatriptan (10 mg or 20 mg).

The other ingredients are potassium dihydrogen phosphate, dibasic sodium phosphate anhydrous, sulphuric acid, sodium hydroxide and purified water.

What Imigran nasal spray looks like and contents of the pack

This medicine is provided in a pre-filled nasal spray device and contains sumatriptan in 0.1 ml of a yellow-coloured solution.

Imigran nasal spray is packed in a box containing the nasal sprays individually sealed in blisters. They are available in packs of 2 and 6 pre-filled nasal spray devices. Each nasal spray contains one dose of Imigran.

Marketing authorisation holder and manufacturer

Marketing Authorisation Holder: Glaxo Wellcome UK Ltd, Stockley Park West, Uxbridge, Middlesex UB11 1BT

Manufacturer: GlaxoSmithKline Manufacturing S.p.A., San Polo di Torrile, Parma, Italy

Other formats:

To listen to or request a copy of this leaflet in Braille, large print or audio please call, free of charge:

0800 198 5000 (UK only)

Please be ready to give the following information:

Product name **Imigran Nasal Spray 10 mg**
 Imigran Nasal Spray 20 mg

Reference number 10949/0260

This is a service provided by the Royal National Institute of Blind People.

Leaflet date: May 2014

IMIGRAN and the IMIGRAN logo are registered trade marks of the GSK group of companies

© 2014 GSK group of companies. All rights reserved